

## For Residential and Commercial Applications

Job Name \_\_\_\_\_  
 Job Location \_\_\_\_\_  
 Engineer \_\_\_\_\_  
 Approval \_\_\_\_\_

Contractor \_\_\_\_\_  
 Approval \_\_\_\_\_  
 Contractor's P.O. No. \_\_\_\_\_  
 Representative \_\_\_\_\_

# LEAD FREE\*

## Series LFWDS FloodSafe® Water Detector Shutoff

Sizes: ¾" and 1" (20 and 25mm)

Series LFWDS Floodsafe® Water Detector Shutoff is a safety valve that protects the home or business owner from catastrophic damage due to a water heater leak. The Series LFWDS detects the presence of water on the floor (or in a drain pan) beneath the water heater and automatically shuts off the water supply and power source to the water heater. The LFWDS features Lead Free\* construction to comply with Lead Free\* installation requirements.

### Features:

- Testable and Resettable: The FloodSafe® Water Detector Shutoff can be easily **reset** by the contractor, home or business owner or plumbing inspector to assure proper operation.
- Lead Free\* cast copper silicon alloy valve body construction
- Easily installed on new or existing water heaters.
  - No special piping is required.
  - Supplied with a Water Dam for concrete, linoleum, tile or other hard surface flooring.
  - Sized for ¾" or 1" (20 or 25mm) water supply lines.
  - Secure interlocking connector cables are unique to each connecting device.
  - Powered by a safe low-voltage power supply that plugs into a standard 120 VAC wall outlet and is wired using standard thermostat cable (supplied by installer).
- Employs state-of-the-art water detection technology (no terminals to corrode or to impair operation).
- Provides contacts for monitored alarm detection systems.
- Power Cutout Modules for the standing pilot gas fired water heaters retain thermocouple circuit in the event of momentary power outage.

### Mechanical

Maximum Pressure: 150psi (10.3 bar)  
 Maximum Temperature: 210°F (99°C)

### Electrical

120 VAC, 70mA, 60Hz  
 Current draw: 50mA  
 Maximum Electric Water Heater current rating: 30A



### Models

- LFWDSP-L Standing Pilot - left-hand thread  
 LFWDSP-R Standing Pilot - right-hand thread  
 LFWDSE220 Electric - 220 VAC  
 LFWDSSI Spark Ignition/Oil Fired

### Specifications

The contractor shall install an electronically actuated resettable shutoff valve on the cold water supply of the water heater, as indicated on the drawing.

The electronically actuated valve shall be a full flow valve that closes upon detection of water at the water detector pad supplied with the valve. Lead Free\* valves shall be constructed using Lead Free\* materials. Lead Free\* Water Detector Shutoff valves shall comply with state codes and standards, where applicable, requiring reduced lead content. A water detector pad shall be installed on the floor beneath the water heater or in a drain pan supplied by the contractor. The water detector pad shall be supplied with an integral cable with connector to connect to the valve control unit. The water detector pad shall be an electronic sensing device.

The electronically actuated valve shall act to shut off both the water supply and the power to the water heater simultaneously upon detection of water.

A visual and audible indication of actuation shall be initiated and normally open contacts suitable for connection to remote monitored alarm actuation shall close.

(Optional: The remote alarm contacts will be connected to a building alarm system by the alarm contractor).

The valve shall be provided with an integral control unit, a water dam, a power supply and a power cutout module in addition to the water detection pad.

\*The wetted surface of this product contacted by consumable water contains less than 0.25% of lead by weight.

## Specifications cont.

All connections to the control unit shall be plug in style unique to the device. Removal of any connector shall result in shut off of the valve.

The valve shall be resettable upon repair of the system or system test.

The Water Detector Shutoff shall be a Watts Series LFWDS.

## How It Works:

- The Control Unit, which houses the circuitry, alarm lamp, audible alarm, alarm silence button, and connector sockets, is installed on the cold water supply piping to the water heater.
- The exclusive Water Detector Pad lays flat on the floor (or in a water heater drip pan).
- Upon detection of as little as 1/16" of standing water, the Control Unit initiates the alarm and shutoff sequence.
  1. **Shuts off the water supply** to the water heater. Closes the cold water supply to the water heater to minimize water leakage and water damage.
  2. **Removes the source of power** to the water heater. If the water detected is from the discharge of a temperature and pressure safety relief valve under emergency conditions, power to the water heater must be removed immediately. This protects your home or business against the danger of explosion.
  3. **Energizes an audible alarm and remote alarm contacts.** The Series LFWDS has an internal alarm to alert the homeowner. It also has contacts that can be connected to monitored alarm systems, to provide 24/7 notification to a home or business security service.

## Dimensions - Weights

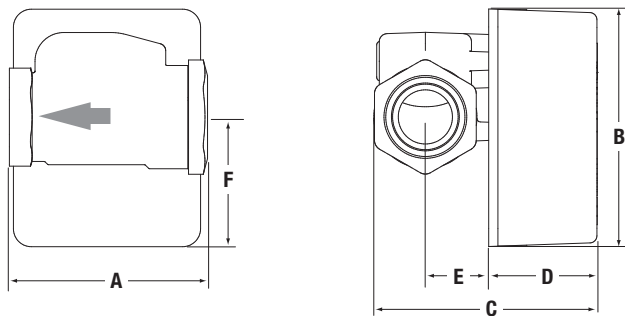

SIZE (DN)		DIMENSIONS								WEIGHT					
in.	mm	A		B		C		D		E		F		lbs.	kgs.
		in.	mm	in.	mm	in.	mm	in.	mm	in.	mm	in.	mm		
3/4	20	3 5/16	84	4 1/8	104	3 5/8	92	1 7/8	48	2 1/4	57	1 5/16	23	2.0	0.9
1	25	3 7/16	87	4 1/8	105	3 7/8	98	1 7/8	48	2 1/4	57	1 1/8	28	2.1	0.9

## Parts included:

### Control Unit

The Control Unit which houses the circuitry for the operation of the valve, contains an interlocking connection for the water detector pad, the power supply, remote alarm and power cutout module.

### Water Dam

The rubber Water Dam can be easily placed around the perimeter of the water heater and cut to the proper length. The dam can be used for concrete, linoleum, tile or other hard surface flooring.

### Water Detector Pad

The Water Detector Pad lays flat on the floor or in a water heater drip pan. The pad employs state-of-the-art sensing technology. There are no terminals to rust or corrode assuring years of maintenance free operation.

### Power Cutout Module

The Power Cutout Module is specific to the LFWDS model; electric, oil fired/spark ignition, or standing pilot. Standing pilot units are used to interrupt the thermocouple, and they are available in right-hand threaded and left-hand threaded models.

## Typical Installations

The FloodSafe® Water Detector Shutoff can be installed in new construction or as an upgrade to existing installations.

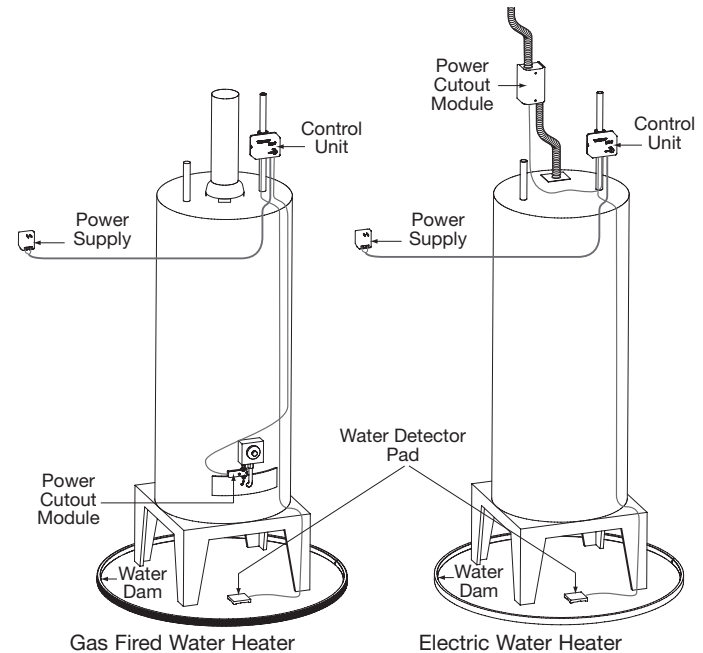

A Watts Water Technologies Company



USA: Tel: (978) 688-1811 • Fax: (978) 794-1848 • www.watts.com  
Canada: Tel: (905) 332-4090 • Fax: (905) 332-7068 • www.watts.ca