

For Residential and Commercial Applications

Job Name _____

Contractor _____

Job Location _____

Approval _____

Engineer _____

Contractor's P.O. No. _____

Approval _____

Representative _____

Series PIPFM1

Isolation Pump Flanges with Purge Port and Swivel Flange

Sizes: $\frac{3}{4}$ " – $1\frac{1}{4}$ "

Series PIPFM1 Isolation Pump Flanges with Purge Port and Swivel Flange are designed to provide circulator pump isolation to facilitate circulator pump replacement or repair while the integral $\frac{1}{2}$ " purge port provides fast system purging.

Features

- Ball valve isolation of circulator pumps
- Integral purge port saves time and money compared to purge stations made with a ball valve, boiler drain and copper tee
- $\frac{1}{2}$ " purge port provides fast complete system purging
- Swivel flange allows purge port to be positioned for optimal purging convenience and provides for neat attractive installations
- Brass body and flange pressure rated to 600 psi (41 bar) WOG
- Stem seal is PTFE adjustable packing design
- Purge port has compact aluminum die cast handle for easy operation

Models

PIPFM1-T $\frac{3}{4}$ " – $1\frac{1}{4}$ " threaded NPT end connection

PIPFM1-S $\frac{3}{4}$ " – $1\frac{1}{4}$ " solder end connection

Specifications

Approved pump flange will be constructed of brass body and adapter with integral brass purge port and a 360° swivel flange for infinite purge port positioning. Stem seal will be adjustable PTFE packing design. Purge port to be $\frac{1}{2}$ " full port design with compact handle. Valve to be Watts Series PIPFM1-T (threaded) or PIPFM1-S (solder).

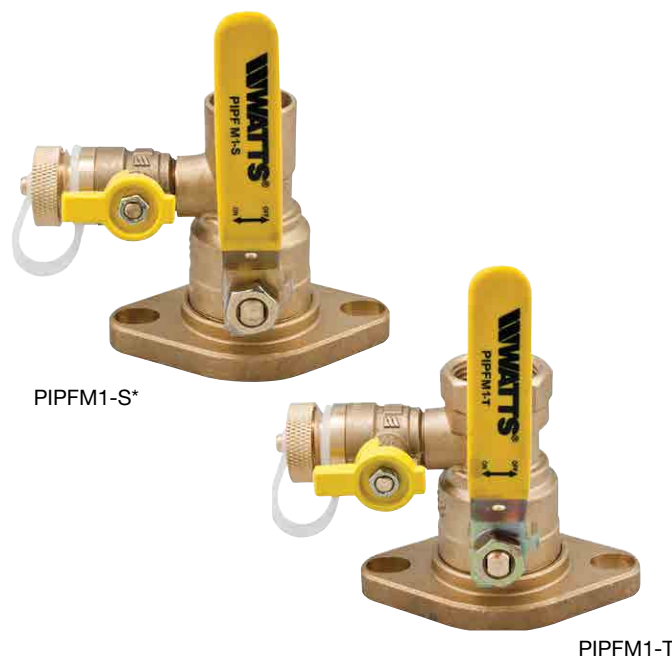

*This valve is designed to be soft soldered into lines without disassembly, using a low temperature solder to 420°F (216°C). Higher temperature solders may damage the seat material.

Apply heat with the flame directed AWAY from the center of the valve body. Excessive heat can harm the seats.

NOTICE

The information contained herein is not intended to replace the full product installation and safety information available or the experience of a trained product installer. You are required to thoroughly read all installation instructions and product safety information before beginning the installation of this product.

Materials

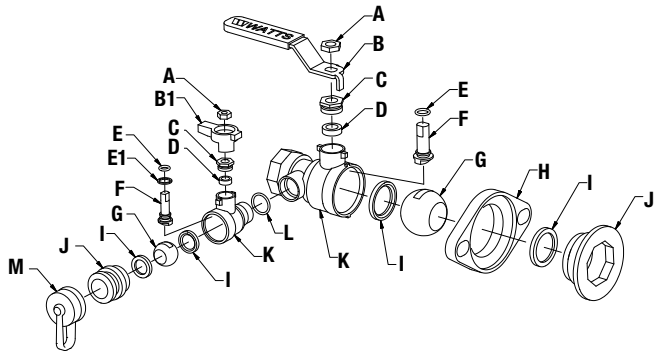

- A. Handle Nut: Zinc Plated Steel
- B. Handle: Zinc Plated Steel with Vinyl Insulator
- B1. Handle: Die Cast Aluminum
- C. Packing Nut: Brass
- D. Packing: PTFE
- E. O-Ring: FKM Elastomer
- E1. Thrust Washer: PTFE
- F. Stem: Brass
- G. Ball: Brass
- H. Flange: Brass
- I. Seat: PTFE
- J. Adapter: Brass
- K. Body: Brass
- L. O-ring: EPDM
- M. Cap & Tether: Brass & Polypropylene

Pressure – Temperature

Maximum Working Pressure: 600psi (41 bar) WOG

Maximum Temperature: 406°F (208°C) @ 100psi (6.9 bar)

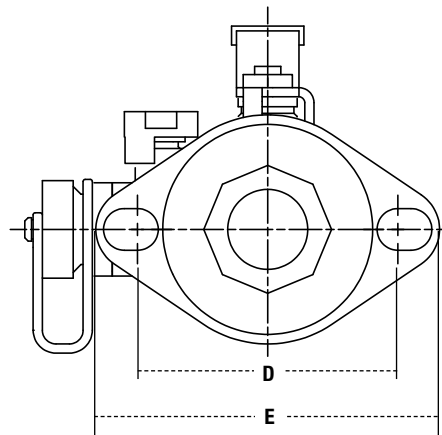
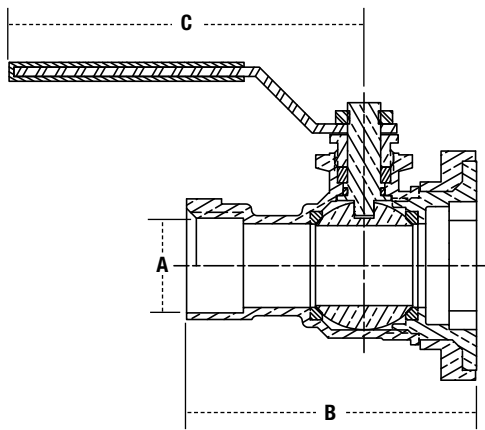

MODEL	SIZE	DIMENSIONS										WEIGHT	
		A		B		C		D		E		lbs.	kg
	in.	in.	mm	in.	mm	in.	mm	in.	mm	in.	mm		
PIPFM1-T	3/4	3/4	19	3 1/8	80	4	101	3 1/8	79	4 1/8	105	2.15	0.98
	1	1	25	3 1/2	88	4 1/4	108	3 1/8	79	4 1/8	105	2.51	1.14
	1 1/4	1 1/4	31	3 13/16	97	4 1/4	108	3 1/8	79	4 1/8	105	2.97	1.35
PIPFM1-S	3/4	3/4	19	3 5/16	84	4	101	3 1/8	79	4 1/8	105	2.09	0.95
	1	1	25	3 11/16	94	4 1/4	108	3 1/8	79	4 1/8	105	2.44	1.11
	1 1/4	1 1/4	31	4 1/16	104	4 1/4	108	3 1/8	79	4 1/8	105	2.88	1.31

